

Technical Manual **CC121**
ARCNET Interface for VMEbus
Version 2.0 **March 1992**

1.1 Introduction

This manual provides general information, preparation for use, installation instructions and theory of operation for the CC121 module. The manual includes basic information needed by software engineers to design and implement software for the module.

1.2 Features

The features of the CC121 module include:

VMEbus Interface

- Double Eurocard form factor
- 7-level interrupt requester with software programmable vector
- Register to mask interrupts or reset ARCNET controller
- 2-kbyte fast dual ported RAM for data packets
- Occupies 4 kbyte of memory in the short or standard address space
- Supervisory mode only, or both supervisory and non-privileged access modes can be selected

Local Area Network

- ARCNET interface for coax or twisted-pair
- Interface signals on front-panel connector and P2
- Uses SMC COM9026 protocol controller
- Selectable high-, or low-impedance coax interface
- Onboard register to read node ID

1.3 General Description

The CC121 ARCNET interface is a VMEbus module that allows to interface VMEbus systems to ARCNET token-passing networks. The board, which is based on the SMC COM9026 ARCNET controller, includes a 2-kbyte high-speed dual-ported RAM data buffer. It operates as a VMEbus slave module with 8-bit access to the controller chip and onboard registers, and 8- or 16-bit access to the data buffer. A separate control register allows the user to mask interrupts from the controller, or reset the board. Another register allows the user to read the ARCNET node ID at any time.

1.4 Related Documents

The following documentation can be referred to for detailed information about related items not described in this manual.

Table 1-1 List of Documents

Document Title	Published by
COM9026 Local Area Network Controller	SMC
IDT7130 CMOS Dual Port RAM (1Kx8)	IDT
ARCNET Cabling Guide (doc nr 51087, ed 2)	Datapoint
ARCNET Local Area Network Standard	Arcnet Trade Association
HYC9088 Twisted Pair or Coax Medium Transceiver	SMC

2.1 Introduction

The CC121 is a network interface module for ARCNET. The module uses a 20-MHz COM9026 protocol controller, and the COM9032 network transceiver. The on-board medium interface is a high-, or low-impedance coax interface or a twisted-pair interface. The coax interface uses a BNC connector at the front panel. The transceiver signals for a twisted-pair interface are available at the VMEbus P2 connector. A twisted-pair interface typically uses an RJ11 connector.

The following section gives an overview of the main parts that are used on the CC121 module.

2.2 Components Used

The local memory consists of two high-speed dual-port RAM devices, that can be accessed by the onboard protocol controller and by a VMEbus master. The memory has a capacity of 2 kbytes, which is used to buffer up to four 512-byte data packets.

The COM9026 device provides the ARCNET network protocol handling. With its 2.5 Mbit/s data rate, up to 255 network nodes, and data packet sizes of up to 512 bytes, the ARCNET local area network is a reliable (token passing), high performance, and low-cost network solution for real-time industrial applications.

The HYC9088 is a hybrid module which interfaces the ARCNET local area network controller to telephone twisted pair, or coax cables.

2.3 General Specifications

Power Requirements

- 1.4 A Max (1.0 A Typ) at +5 VDC
- 240 mA Max (180 mA Typ) at -12 VDC

Physical Configuration Options

- Size: 160 mm x 233.35 mm x 20 mm
- Weight: 330 gram

Environmental Requirements

- Operating temperature: 0 to 70 degrees C
- Max operating humidity: 90%

2.4 VMEbus Specifications

Data Transfer Options

- A24,A16/D16,D8 RMW slave
- DPR read access: 120 ns (typ)
DPR write access: 120 ns (typ)
- DPR cycle time: 150 ns (typ)

Interrupt Options

- D08(O)/I(1,2,3,4,5,6,7) static
- Programmable vector
- ROAK interrupter

2.5 Network Specifications

Network Interface Options

- 2.5 Mbit/s ARCNET interface
- Coax medium interface: RG62A/U cable
- Onboard termination (jumper selectable)
- Onboard BNC connector
- Twisted-pair medium interface: RS-485
- Off-board RJ11 connector

3.1 Introduction

This chapter gives an overview of the CC121 module, and a detailed description of the functional sections. The block diagram of the module is given in Appendix A

Signal names that are used in the schematic diagrams, have a horizontal bar (-) or end with an asterisk (*), when the signal is active low.

3.2 VMEbus Interface

The VMEbus interface is used by to access resources on the CC121 module. These resources include a 2-kbyte dual-port data buffer, the ARCNET protocol controller, and some general control registers. The data buffer is used to hold data packets temporarily prior to transmission on the network and as a temporary storage of all received data packets directed to this particular node. The processor writes commands to the protocol controller and can read its status. The onboard control registers are used to read the ARCNET node ID, and to control the interrupt function of the board.

The CC121 occupies 4-kbytes in the VMEbus standard, or short I/O address space. The address selection is made with hexadecimal switches, and the address modifiers are selected with jumpers. The interrupt level is also selected with jumpers, and the interrupt vector is software programmable.

3.3 ARCNET Interface

The COM9026 is used to implement the ARCNET interface. This device has a microprocessor interface with low-overhead software requirements. It establishes the network configuration, and automatically re-configures the network as new nodes are added or deleted from the network. The 8-position DIP switch on the CC121 module is used to select the ARCNET node ID.

The CC121 module supports three ARCNET medium interfaces, that all have specific advantages for different environments. The RG-58 coax cable is the most often used medium, and uses a standard BNC connector on the front panel. Onboard cable termination has been implemented and can be selected with a jumper.

The lowest cost network medium is a telephone twisted pair cable, and uses the P2 connector for connection to the network.

Dual-Port Memory

The data buffer, used by both the microprocessor and protocol controller to transfer data packets, has been implemented as a dual-port RAM. This memory configuration dramatically improves the memory

access time, because the VMEbus master can transfer data packets to/from this memory using high-speed 16-bit transfers.

4.1 Introduction

This chapter provides the preparation and installation instructions for the CC121 ARCNET interface module.

4.2 Installation

The module is shipped in an anti-static container which protects it against static electricity. When the module is unpacked, avoid touching areas of integrated circuitry to prevent static discharge from damaging the circuits.

Before the module can be used, several on-board switches and jumpers must be checked for proper settings. Jumpers are used to select hardware specific options.

NOTE: ENSURE THAT POWER IS TURNED OFF BEFORE INSERTING OR WITHDRAWING THE CC121 MODULE IN OR FROM THE SYSTEM BACKPLANE.

4.3 Jumper Settings

All jumper settings discussed in the following sections are illustrated as seen from the component side with the VMEbus connectors downwards. The next table gives a summary of the default jumper and switch settings and their function.

Table 4-1 Jumper Setting

Description	Jumper Block	Default Setting	Status	Section
Network Time Out	JB1	Not Connected	Max. 4 miles	4.3.1
Cable Ground	JB2	1-2 Connected	VMEbus GND	4.3.2
IRQ Level	JB3	5-6 Connected	Level 3	4.3.3
Access Mode	JB4	Not Connected	Both sup. and n.p.	4.3.4
Addressing Mode	JB5	2-3 Connected	Short addressing	4.3.4
Coax Termination	JB6	Not Connected	High Impedance	4.3.5
Node ID	SW1	Switch 5 ON, rest OFF	Node ID \$10	4.3.6
Address (A15-A12)	SW2	'D'	Address \$D000	4.3.4
Address (A19-A16)	SW3	'F'	Don't care	4.3.4
Address (A23-A20)	SW4	'F'	Don't Care	4.3.4

4.3.1 Network Time Out Selection

There are three time-outs associated with the COM9026 operation. These time-outs are referred to as Response Time, Idle Time, and Reconfiguration Time. The ARCNET protocol relies on a token passing scheme. If any node does not receive the token within the Reconfiguration Time, the node will initiate a Network Reconfiguration.

Two jumper blocks have been provided to increase the time-out periods, which allow the network to operate over longer distances than 4 miles.

Table 4-2 Time Out Values

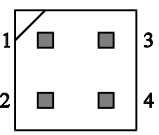
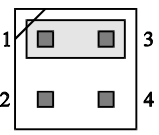
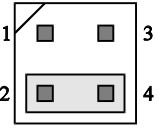
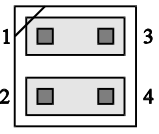
JB1	Response Time	Idle Time	Reconfiguration Time
	78 μ s	86 μ s	840 ms
	285 μ s	316 μ s	1680 ms
	563 μ s	624 μ s	1680 ms
	1130 μ s	1237 μ s	1680 ms

The default time-out setting for a typical ARCNET network requires no jumpers at JB1.

For proper working of the ARCNET protocol, it is necessary that all nodes connected to the network use the same time-out periods.

4.3.2 Cable Ground Decoupling

The signal lines of the ARCNET medium for twisted pair and coax are decoupled with an RC network. The user can select with JB2 whether the decoupling is to VMEbus GND or to Chassis GND. If “chassis GND” is selected, a proper chassis GND connection must exist at pin 3 of row C of the P2 connector.

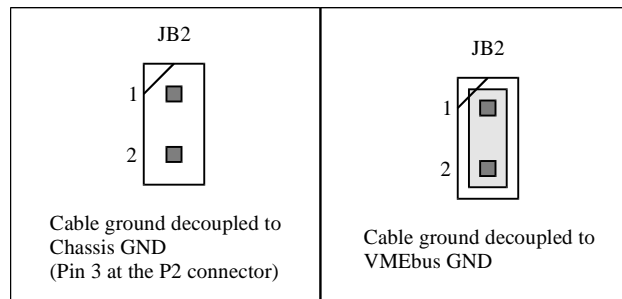

Figure 4-1 Cable Ground Decoupling

4.3.3 VMEbus Interrupt Level

JB3 allows the user to select the interrupt level that is generated on the VMEbus. JB3 is decoded as a 3-bit binary input. A jumper installed represents a “0”. No jumper installed represents a “1”. When level 0 is selected (i.e. all jumpers installed), the interrupt function will be disabled. The figure on the next page shows the possible jumper settings and their status.

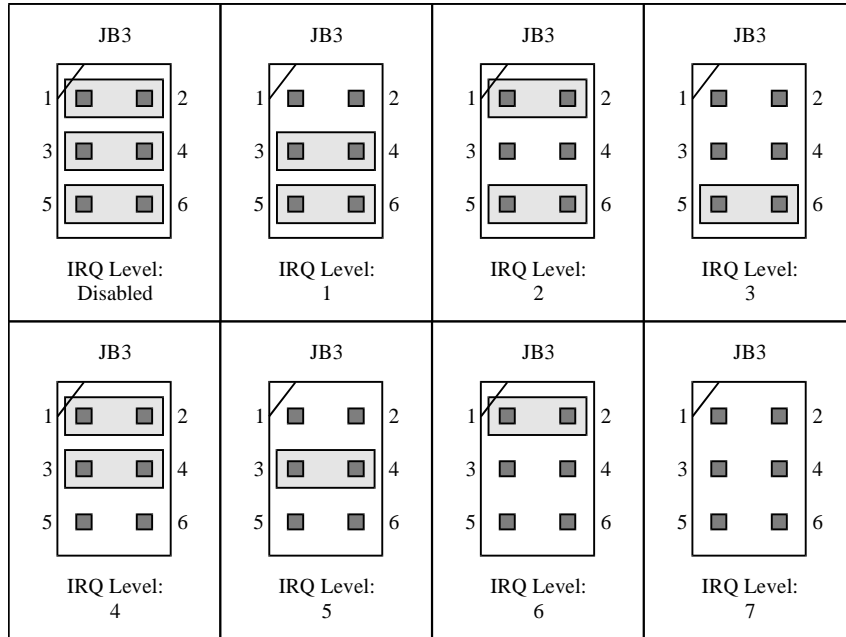

Figure 4-2 Interrupt Level Selection

4.3.4 VMEbus Address Selection

To access resources on the CC121, the VMEbus master may use standard or short addressing, and supervisory and/or non-privileged access. Two jumpers and three hex switches are used to select the address mode and address of the CC121 module.

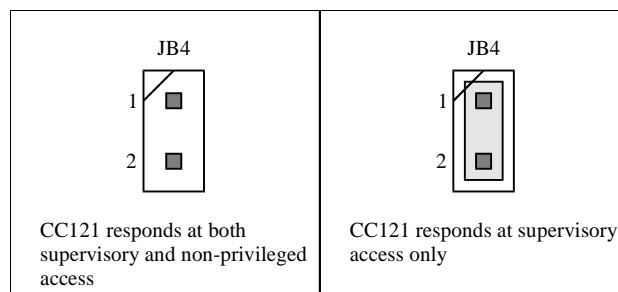

Figure 4-3 CC121 Access Mode

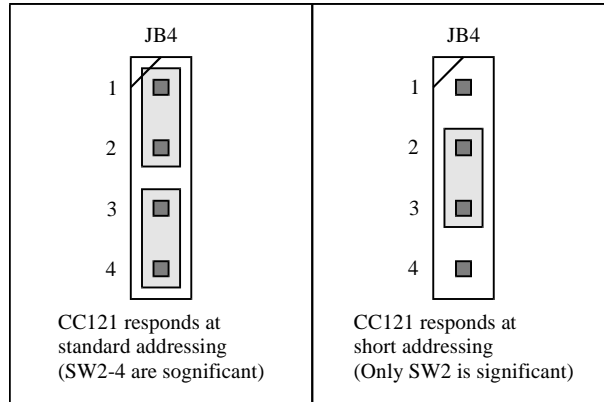

Figure 4-4 CC121 Address Mode

Three hex switches (SW2, SW3, and SW4) are used to select the base address of the CC121 module.

Address Lines	A23-A20	A19-A16	A15-A12	A11-A1
Hex Switch	SW4	SW3	SW2	
Base Address Example	F	F	D	0 0 0

Figure 4-5 Base Address Selection

4.3.5 ARCNET Coax Termination

The coax interface for the ARCNET local area network uses a BNC connector. At both ends of the network segment, the coaxial cable must be terminated.

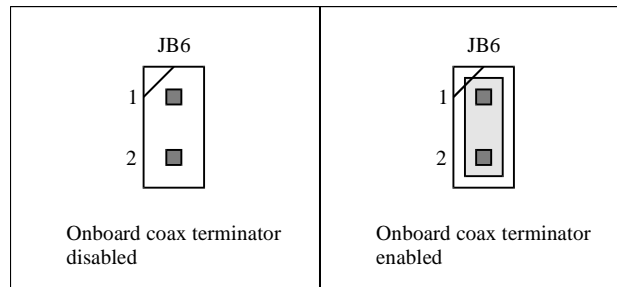

Figure 4-6 Onboard Coax Termination

The terminating resistor can be placed at the cable, using a T-connector with a BNC terminator, or the onboard terminator on the CC121 can be used. Jumper JB6 is used to select the cable termination on

the CC121 module. When a jumper is installed the coax cable is terminated with the onboard terminating resistor of 93 Ohms. This resistor has the proper value for RG62A/U type of coaxial cable. When no jumper is installed, the coax connector represents a high-impedance cable interface.

4.3.6 Node ID Switch SW1

An 8-position DIP switch is implemented, that is used to select the ARCNET Node ID of the CC121 module. The switch setting is used by the COM9026 and can be read by the MPU. The switches are numbered from 1 through 8, and each switch can be put “on” or “off”. An “on”-position is read as “0”, while an “off”-position is read as “1”. Position 8 represent the most significant bit and position 1 the least significant bit of the 8-bit Node ID.

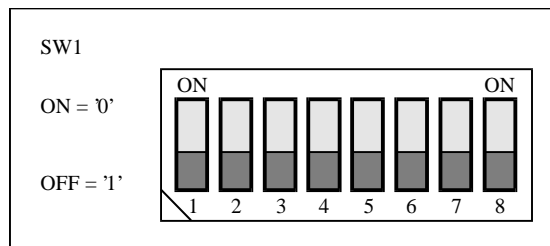

Figure 4-7 Node ID Switch

4.4 Network Medium

The CC121 can be used for different types of network media. The next table shows the possible options. Note that ARCNET allows the usage of different cable types on the same network.

Table 4-3 Network Medium Options

Medium	Connector	Type of Cable	Medium Transceiver
Coax	BNC	RG62A/U coax cable	HYC9088 Hybrid
Twisted-pair	RJ11	Telephone twisted-pair	HYC9088 Hybrid (RS-485)

The type of medium that is used depends on the installed medium transceiver. When the HYC9088 medium transceiver is used, the selection between a coax or a twisted-pair medium is made by the proper installation of the network decoupling circuits.

The medium option is selected during the production phase of the module.

4.4.1 Coax Interface

The coax medium uses a front-panel BNC connector, or is connected via the VMEbus P2 connector. The following circuit diagram applies to the coax interface on the CC121.

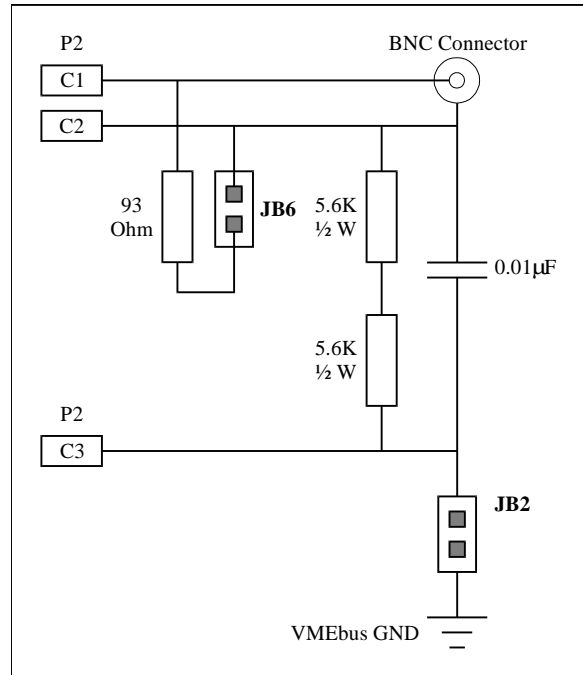

Figure 4-8 Coax Interface

4.4.2 Twisted Pair Interface

The twisted pair interface is available at the VMEbus P2 connector and has the following circuit diagram. Note that the RJ11 connector is placed outside the CC121 module.

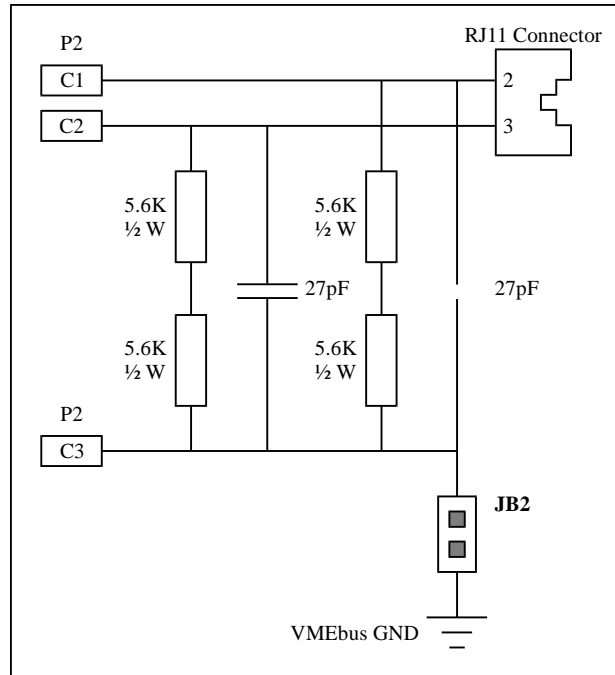

Figure 4-9 Twisted Pair Interface

Programming Considerations

5.1 Introduction

This section contains all necessary information for system programmers to take full advantage of the features of the CC121 module. The descriptions will include implementation dependent information that cannot be found in the respective data sheets. This chapter should be used in conjunction with the references given in paragraph 1.4.

System programmers are expected to be fully conversant with all the material mentioned in paragraph 1.4 and have the relevant experience, when they want to write their own system software.

In Appendix C, the Memory map of the CC121 module is given. It also shows the register map of the peripherals.

5.2 Reset

When power is applied to the CC121 module, or the VMEbus SYSRESET* signal is activated, the onboard devices will be reset. These devices include the COM9026, the COM9032, and the board control register. After reset the ARCNET protocol controller will perform an internal initialization cycle, and reads its node ID from the Node ID switch. The COM9026 will also generate a reset interrupt. Note that this interrupt will not immediately generate a VMEbus interrupt, because the interrupt enable bit of the board control register is cleared during reset.

After successful initialization, the COM9026 will execute two write cycles to the dual-port RAM. Location 00 will be written with D1 (hex), and location 1 will be written with the Node ID value, as it was read from the Node ID switch. Only when the VMEbus master reads these patterns from the dual-port RAM, proper operation of the COM9026 is assured.

5.3 CC121 Memory Map

The local memory map takes a total of 4 kbytes in the VMEbus standard or short address space. It has been divided in two 2-kbyte segments, where the first part is used to access the dual-port data buffer, and the second part the 8-bit devices.

The total memory map is shown in the next table. Note that address spaces marked with (*), are repeated a number of times in the memory map. The number of times depends on the space that the peripheral occupies in the memory map. The size indication shows the allowed data transfer width.

Note that only the 2-kbyte data buffer can be accessed for 16-bit transfers. The other peripherals must be accessed for 8-bit transfers and addressed at odd memory locations.

Table 5-1 CC121 Memory Map

Address	Device	Size
xxx000 xxx7FF	Dual-port Data Buffer 2Kbyte	8, 16 bit
xxx800 xxx9FF	COM9026 (*) 2 bytes	8 bit
xxxA00 xxxBFF	Interrupt Vector Register (*) 1 byte	8 bit
xxxC00 xxxDFF	Board Control Register (*) 1 byte	8 bit
xxxE00 xxxxFFF	Node ID Switch Register (*) 1 byte	8 bit

The next sections describe the devices in the memory map in more detail.

5.3.1 Dual-port Data Buffer

The data buffer is used to hold data packets temporarily prior to transmission on the network and as a temporary storage of all received data packets directed to the particular node. The 2-kbyte RAM buffer allows both transmit and receive operations to be double buffered with respect to the processor (VME-bus master). For instance, after one data packet has been loaded into a particular page within the data buffer and a transmit command for that page has been issued, the processor can start loading another page with the next message. Similarly, after one message is received and completely loaded into one page of the RAM buffer by the COM9026, another receive command can be issued to allow reception of the next packet while the first packet is read by the processor.

5.3.2 COM9026 ARCNET Interface

The COM9026 Local Area Network Controller (LANC) has been implemented to provide the ARCNET network interface. The chip contains an internal microsequencer which performs all of the control operations necessary to carry out the ARCNET protocol. The COM9026 contains a 'write interrupt mask' register, a 'read status' register, and a 'write command' register. The MPU controls the COM9026 via software, by accessing the various registers. These actions are described in the data sheet. The next figure shows the registers of the protocol controller.

Read Status Register Register									
Address	7	6	5	4	3	2	1	0	
\$xxx801	RI	ETS2	ETS2	POR	TEST	RECON	TMA	TA	
	R	R	R	R	R	R	R	R	
Write Interrupt Mask Register									
Address	7	6	5	4	3	2	1	0	
\$xxx801	RI					RECON		TA	
	W	W	W	W	W	W	W	W	
Write Command Register									
Address	7	6	5	4	3	2	1	0	
\$xxx803	Command Byte								
	W	W	W	W	W	W	W	W	

Figure 5-1 COM9026 Registers

- RI** Receive Inhibit - This bit, if set high, indicates that a packet has been deposited into the RAM buffer page nn as specified by the last ENABLE RECEIVE TO PAGE nn command. The setting of this bit can cause an interrupt if the corresponding mask bit in the interrupt mask register and the interrupt enable bit in the board control register have been properly setup. No messages will be received until an ENABLE RECEIVE TO PAGE nn command is issued. After any message is received, the receiver is automatically inhibited by setting this bit to a logic one.
- ETS2** Extended Time Out Status 2 - This bit reflects the current logic value of the ETS2 input pin, as determined by JB1.
- ETS1** Extended Time Out Status 1 - This bit reflects the current logic value of the ETS2 input pin, as determined by JB1.
- POR** Power On Reset - This bit, if set high, indicates that the COM9026 has been reset. The setting of this bit will cause an interrupt, if the enable interrupt bit of the board control register has been set. This bit is cleared by writing the CLEAR FLAGS command to the command register.
- TEST** Test - This bit is intended for test and diagnostic purposes. It will be a logic zero under any normal operating conditions.
- RECON** Reconfiguration - This bit, if set high, indicates that the reconfiguration timer has timed out because the RX input was idle for 78.2 μ s (typ). The setting of this bit can cause an interrupt if the corresponding mask bit in the interrupt mask register and the interrupt enable bit in the board control register have been properly setup. The bit is reset low during a CLEAR FLAGS command.
- TMA** Transmit Message Acknowledge - This bit, if set high, indicates that the packet transmitted as a result of an ENABLE TRANSMIT FROM PAGE nn command has been positively acknowledged. This bit should only be considered valid after the TA bit is set. Broadcast messages are never acknowledged.
- TA** Transmit Available - This bit, if set high, indicates that the transmitter is available for transmitting. This bit is set at the conclusion of an ENABLE TRANSMIT FROM PAGE

nn command or upon execution of a DISABLE TRANSMITTER command. The setting of this bit can cause an interrupt if the corresponding mask bit in the interrupt mask register and the interrupt enable bit in the board control register have been properly setup.

The valid command bytes that can be written to the command register are showed in the next table.

Table 5-2 COM9026 Command Bytes

Command Byte	Description
0000 0000	RESERVED
0000 0001	DISABLE TRANSMITTER
0000 0010	DISABLE RECEIVER
000n n011	ENABLE TRANSMIT FROM PAGE nn
b00n n100	ENABLE RECEIVE TO PAGE nn (b determines if broadcast messages are to be received)
0000 c101	DEFINE CONFIGURATION
000r p110	CLEAR FLAGS (Reconfiguration and Power on)

5.3.3 Interrupt Vector Register

The interrupt output of the COM9026 is connected to the selected interrupt line on the VMEbus. JB3 is used to select the interrupt level on the VMEbus. The interrupt vector provided during an interrupt acknowledge cycle is software programmable by writing to the interrupt vector register.

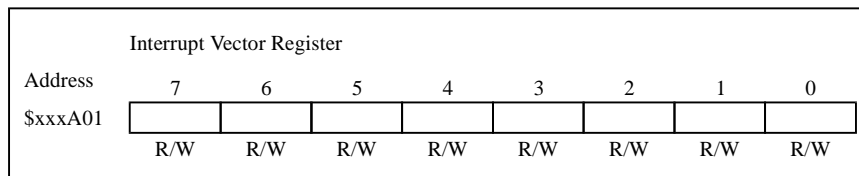

Figure 5-2 Interrupt Vector Register

5.3.4 Board Control Registers

The board control register is used to generate a local reset to the CC121 board, and to control the interrupt output.

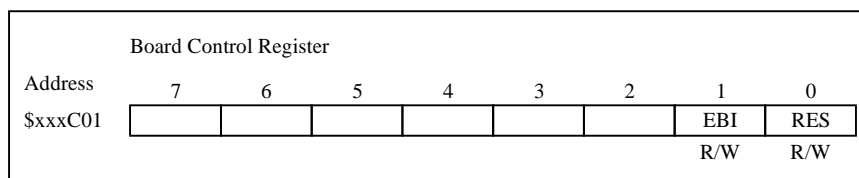

Figure 5-3 Board Control Register

EBI	Enable Board Interrupt - If this bit is set, the interrupt output to the VMEbus is enabled. After reset this bit is cleared, which disables the interrupt output.
RES	Reset - This bit is used to reset the COM9026 by writing a '1' followed by a '0'. The time between the two consecutive write cycles determines the reset time and must be at least 2 μ s. This bit is cleared after a VMEbus reset.

5.3.5 Node ID Switch

An on-board DIP switch has been implemented, which setting can be read by the MPU at address \$xxxE01. The register at \$xxxE01 is read-only. The following figure shows the bit assignments of the register.

Node ID Register																	
Address	7 6 5 4 3 2 1 0																
\$xxxE01	<table border="1"> <tr> <td>SW8</td> <td>SW7</td> <td>SW6</td> <td>SW5</td> <td>SW4</td> <td>SW3</td> <td>SW2</td> <td>SW1</td> </tr> <tr> <td>R</td> <td>R</td> <td>R</td> <td>R</td> <td>R</td> <td>R</td> <td>R</td> <td>R</td> </tr> </table>	SW8	SW7	SW6	SW5	SW4	SW3	SW2	SW1	R	R	R	R	R	R	R	R
SW8	SW7	SW6	SW5	SW4	SW3	SW2	SW1										
R	R	R	R	R	R	R	R										

Figure 5-4 Node ID Register

A switch that is in the 'on' position will read as '0', and the 'off' position will read as '1'.

Appendix A Block Diagram

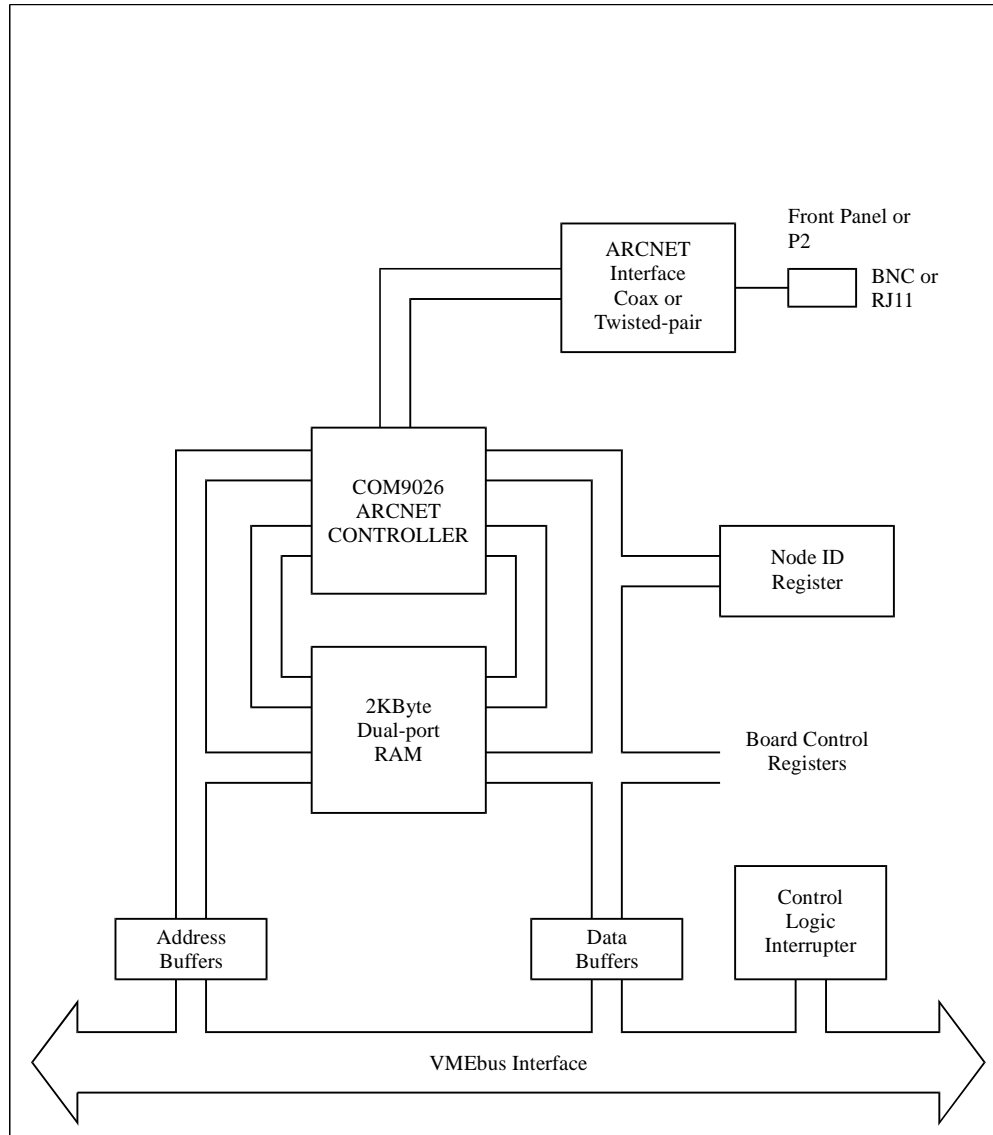

Figure A-1 CC121 Block Diagram

Appendix B Connector Assignments

This Appendix identifies the VMEbus connectors P1 and P2.

Note: Signal mnemonics that are shown in parenthesis are not used by the CC121 module.

Table B-1 VMEbus P1

Pin Number	(a) Signal Mnemonic	(b) Signal Mnemonic	(c) Signal Mnemonic
1	D00	(BBSY*)	D08
2	D01	(BCLR*)	D09
3	D02	(ACFAIL*)	D10
4	D03	BG0IN*	D11
5	D04	BG0OUT*	D12
6	D05	BG1IN*	D13
7	D06	BG1OUT*	D14
8	D07	BG2IN*	D15
9	GND	BG2OUT*	GND
10	(SYSCLK)	BG3IN*	(SYSFAIL*)
11	GND	BG3OUT*	BERR*
12	DS1*	(BR0*)	SYSRESET*
13	DS0*	(BR1*)	LWORD*
14	WRITE*	(BR2*)	AM5
15	GND	(BR3*)	A23
16	DTACK*	AM0	A22
17	GND	AM1	A21
18	AS*	AM2	A20
19	GND	AM3	A19
20	IACK*	GND	A18
21	IACKIN*	(SERCLK)	A17
22	IACKOUT*	(SERDAT*)	A16
23	AM4	GND	A15
24	A07	IRQ7*	A14
25	A06	IRQ6*	A13
26	A05	IRQ5*	A12
27	A04	IRQ4*	A11
28	A03	IRQ3*	A10
29	A02	IRQ2*	A09
30	A01	IRQ1*	A08
31	(-12V)	(+5V STDBY)	(+12V)
32	+5V	+5V	+5V

Table B-2 VMEbus P2

P2 Pin Number	Row A Signal Mnemonic	Row B Signal Mnemonic	Row C Signal Mnemonic
1		+5 VOLT	CNTR
2		GND	SHLD
3		(RESERVED)	CGND
4		(A24)	
5		(A25)	
6		(A26)	
7		(A27)	
8		(A28)	
9		(A29)	
10		(A30)	
11		(A31)	
12		GND	
13		+5 VOLT	
14		(D16)	
15		(D17)	
16		(D18)	
17		(D19)	
18		(D20)	
19		(D21)	
20		(D22)	
21		(D23)	
22		GND	
23		(D24)	
24		(D25)	
25		(D26)	
26		(D27)	
27		(D28)	
28		(D29)	
29		(D30)	
30		(D31)	
31		GND	
32		+5 VOLT	

Memory and Peripheral Map

Table C-1 CC121 Memory Map

Address	Device	Size
xxx000 xxx7FF	Dual-port Data Buffer 2Kbyte	8, 16 bit
xxx800 xxx9FF	COM9026 (*) 2 bytes	8 bit
xxxA00 xxxBFF	Interrupt Vector Register (*) 1 byte	8 bit
xxxC00 xxxDFF	Board Control Register (*) 1 byte	8 bit
xxxE00 xxxFFF	Node ID Switch Register (*) 1 byte	8 bit

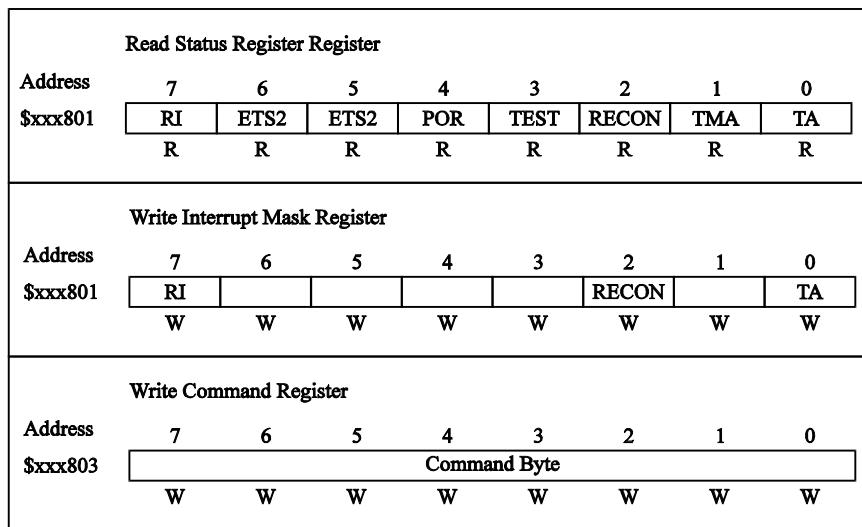

Figure C-1 LANC (COM9026) Register Map

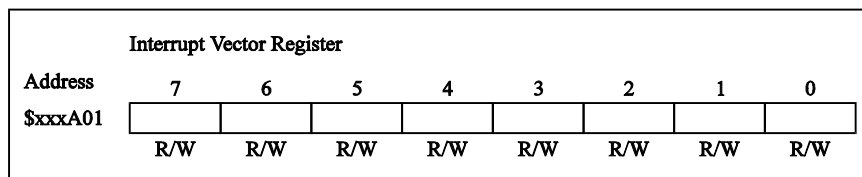

Figure C-2 Interrupt Vector Register

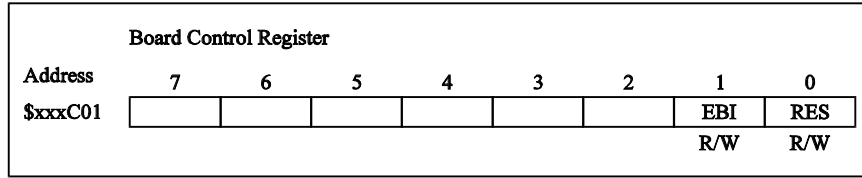

Figure C-3 Board Control Register

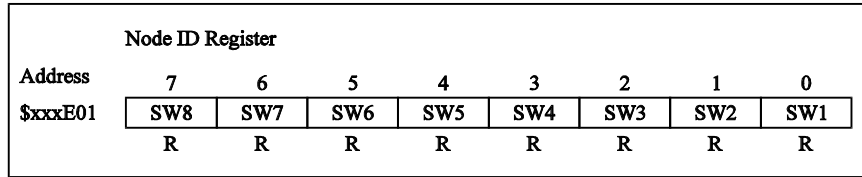

Figure C-4 Node ID Register

Placeholder

Figure D-1 Photo CC121 Board

